

A hug of warmth wrapped in nature.

V-Guard Air Source Heat Pump Water Heaters.



Air Source Heat Pump Water Heater (ASHPWH)

Running hot water, in recent times has become a necessity more than a luxury. An Air Source Heat Pump Water Heater (ASHPWH) from V-Guard is the go-to solution for readily available hot water. Our ASHPWH's work even when the outside temperature is way less than zero degrees Celsius. They are energy efficient and save on fuel cost as the heat is absorbed from the atmosphere. Like every other product from V-Guard, the smallest detail has been looked at to make sure that only the best product reaches our valuable customer.

V-Guard Air source heat pump water heaters are usually said to be "fit and forget" units. If you have bought a V-Guard heat pump water heater, rest assured, you have bought arguably the best product in its category with best in class features in safety, efficiency, power saving and environment protection.



Lower
operating cost



MODBUS
Communication



Environmental
friendly refrigerant



Less
Maintenance



Silent
Operation





Features

- MODBUS Communication: V-Guard Heat Pump Water Heater use MODBUS communication protocol. It can be easily integrated into most existing building management systems without hassle.
- V-Guard ASHPWHs use High efficiency Tube in shell heat ex-changer that ensures high Coefficient of performance (COP) which equates to lower operating cost.
- Environmental friendly refrigerant: our heat pumps only use environment friendly R410A refrigerant.
- V-Guard ASHPWHs provide constant temperature output ranging from 55-60 Degree Celsius.
- V-Guard ASHPWHs come integrated with high pressure protection systems that ensures safety.
- Automatic defrost ensures that maintenance and cleaning intervals do not come too often.
- V-Guard ASHPWHs operates on vast range of temperature variation ranging from -15 to 43 Degree Celsius.
- V-Guard ASHPWHs comes equipped with a water resistant body. They are coated with an anti-corrosive coating that ensures long lasting maintenance free operation.
- Our systems are easy to install and backed by hassle free service.

Working Principle - Heat Pump Water Heater:

The heat pump makes use of a refrigerant for its operation. The low temperature refrigerant absorbs free heat from the atmospheric air in the evaporator is compressed by a highly efficient electrical compressor to a high- temperature and high-pressure vapour refrigerant. This vapour is then passed through a heat exchanger (condenser) to transfer the heat to the water in the storage tank to produce hot water. The refrigerant then passes through an expansion valve and it goes back to the evaporator for absorbing the free heat from the atmospheric air again and the cycle is repeated.

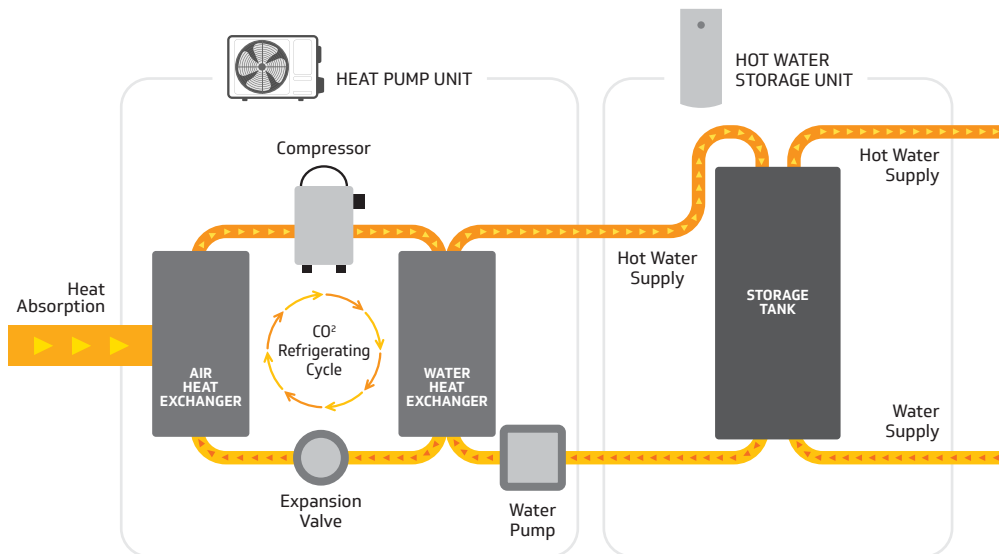

Working of Heat Pump Water Heater in a SWH System as a Backup

- In a SWH system, heat pump acts as a backup heating even when there is cloudy weather or the solar radiations available is very scarce
- There are separate pipes provided in the solar water heater storage tank for circulating cold water from SWH tank to Heat pump and hot water from Heat Pump to SWH tank
- To integrate the heat pump in the SWH system, it requires a hot water circulation pump and a digital temperature controller with sensors
- Whenever the temperature in the SWH drops below the set value, the pump starts circulating the water through the heat pump and heats it up to the set temperature. On reaching the set temperature, the pump stops automatically after sensing the temperature in the storage tank

Heat Pump Water Heater Installation Diagram

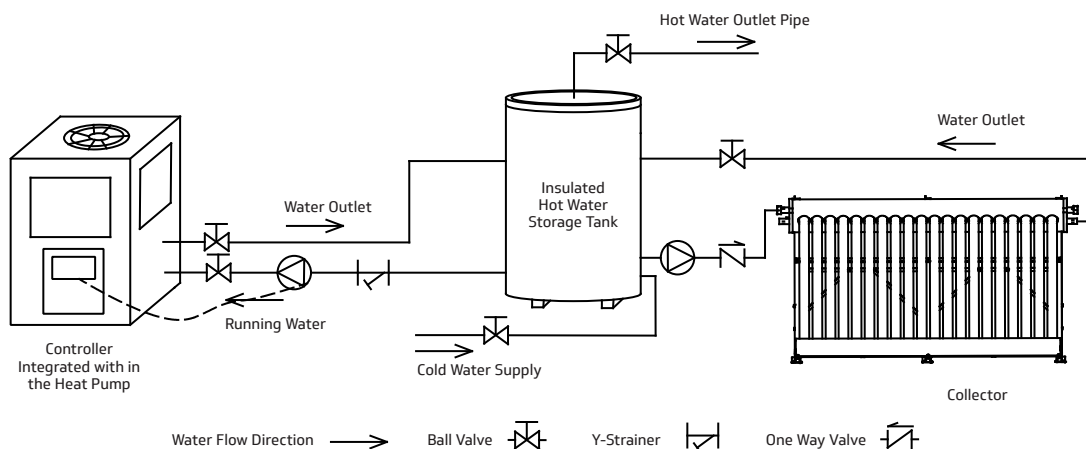

Applications

- Residential Bungalow
- Apartments
- Hospitals
- Swimming Pool
- Industrial Applications
- Hotels / Resorts



Specifications

V-Guard HP Model Name	V-HP 1 T	V-HP 1.5 T	V-HP 2 T	V-HP 3 T	V-HP 5 T	V-HP 6 T	V-HP 10 T	V-HP 15 T
Power Supply	220V/50Hz	220V/50Hz	220V/50Hz	220V/50Hz	380V/3/50Hz	380V/3/50Hz	380V/3/50Hz	380V/3/50Hz
Heating Capacity at Air 25°C/20°C, Water Temperature from 20°C to 55°C								
Heating Capacity (kW)	4.1	6.2	8.6	12.0	21	28	43	55
Power Input (kW)	0.97	1.46	2.03	2.82	4.9	6.5	9.9	12.6
COP	4.21	4.26	4.24	4.25	4.29	4.28	4.34	4.36
Max Power Input (kW)	1.45	2.01	2.75	3.35	6.9	9.2	13.2	16.8
Max Current (A)	6.5	9.1	12.5	15.2	12.3	16.4	13.2	31.5
Rated Hot Water (L/h)	100	150	200	300	515	690	1050	1380
Refrigerant	R410a	R410a	R410a	R410a	R410a	R410a	R410a	R410a
Expansion Valve	Electronic	Electronic	Electronic	Electronic	Electronic	Electronic	Electronic	Electronic
Air Flow Direction	Horizontal	Horizontal	Horizontal	Horizontal	Vertical	Vertical	Vertical	Vertical
Wilo Water Pump	RS-15/6		RS-25/8		PUN-402EH		PUN-750EH	
Water Pressure Drop (kPa)	35	35	40	45	50	50	50	55
Net Dimensions(L*W*H) (mm)	936×385×550		1011×420×614		755×695×1000		1417×755×1000	
Working Temperature Range (°C)	-15~43	-15~43	-15~43	-15~43	-15~43	-15~43	-15~43	-15~43
Noise (dB)	47	49	52	53	≤60	≤60	≤65	≤65
Net Weight (Kg)	50	54	68	74	160	185	259	305
Water connection(mm)	20	20	20	20	25	25	32	40
Warranty	2 Year	2 Year	2 Year	2 Year	2 Year	2 Year	2 Year	2 Year

Heating Cost Comparison

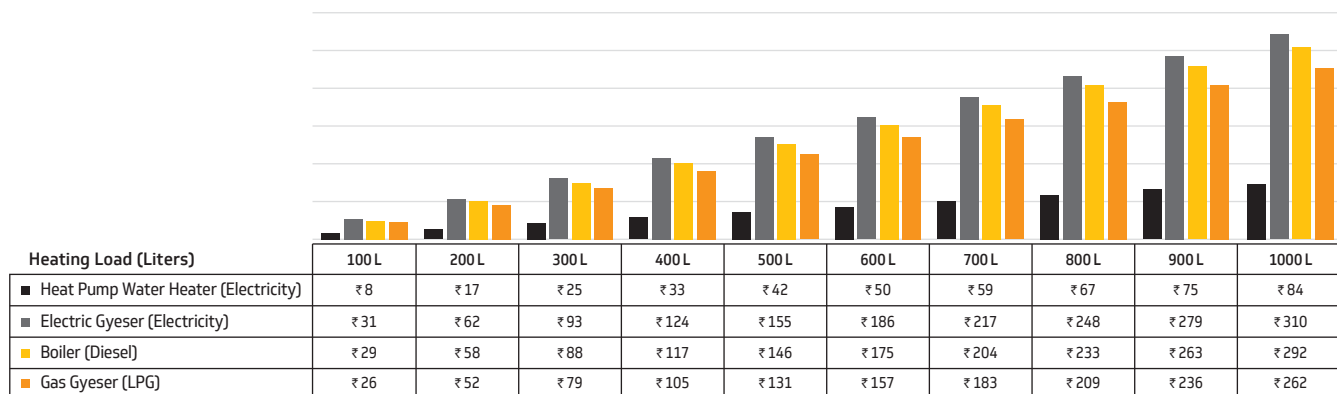



V-Guard Industries Ltd.,
Registered Office: 42/962,
Vennala High School Road,
Vennala, Kochi - 682028, Kerala.
Ph: 0484-2005000, 4335000
www.vguard.in



V-Guard Care
1800 103 1300 (Toll Free)
1860 180 3000 (Charges Apply)
customercare@vguard.in | www.vguardservice.in
CIN: L31200KL1996PLC010010